

**SHERWOOD**

**SPECIALTY**

**GAS**

**VALVES**

# **BEYOND SPECIALTY GAS ... QUALITY PRODUCTS FOR DIVERSE MARKETS.**

**Sherwood's years of experience in the diverse product lines of compressed gas propane, specialty gas and life support provide us with the technical expertise to meet your varied needs. Sherwood is your partner for the best quality valves, delivered on time, at the best possible price!**



## **A History of Quality and Innovation**

***For nearly a century, Sherwood has been the world's leading provider of system-critical compressed gas solutions serving blue-chip bulk and specialty gas manufacturers, distributors, and storage & delivery system providers (OEMs).***

**Sherwood had its beginnings in Buffalo, NY in 1923. Over the last 90 years, we have earned a reputation for products that not only keep pace with customer requirements, but also anticipate their changing needs. Our expert engineering and product development teams continuously work to improve Sherwood's core competencies and create new, innovative products to meet the industry's ever-changing standards and demands.**

**In 1996, Sherwood merged with Taylor-Wharton. Today Sherwood Valve has three manufacturing facilities near Pittsburgh, PA and Cleveland, OH.**

**Automated manufacturing processes throughout Sherwood's operations are set up to eliminate 97% of all touch labor, resulting in consistently higher-quality products. We've added many new advanced process controls, including infrared thermal imaging to ensure optimization at every stage in the manufacturing process, and helium leak checking for quality, safety and reliability.**

**We're using the latest technology available to lower costs and increase quality. For example, Sherwood's Industrial Automation Center produces up to 6,500 assembled and tested valves per shift. And to help ensure quality for our customers, this equipment features automated self-diagnostic and maintenance procedures that increase manufacturing efficiency and output.**

**Sherwood is a totally integrated brass valve manufacturer. We manufacture our own rod and raw forgings at our foundry. These forgings are then machined into the bodies that we use in our valves. Because we manufacture our own brass rod, we can control the alloy components more closely, resulting in a more durable forging.**

**All Sherwood products are designed to meet the highest standards, and only quality materials are used. For example, Sherwood's specialty gas products for medical and breathing apparatuses are cleaned and assembled in a strictly controlled, clean environment. Careful assembly and detailed inspection of every part ensures top performance and durability. Sherwood is fully certified to the stringent requirements of ISO 9001, which increase manufacturing efficiency and reliability.**

**Sherwood's diverse product lines of specialty gas, compressed gas, refrigeration products, propane and life-support equipment have enabled us to develop varied and diverse technical expertise. Our engineering team includes experts in product design and development as well as experts in the quality and compliance testing requirements needed to create custom valves to meet your unique applications.**

**Sherwood is partnered with a solid network of worldwide industry leaders, distributors, manufacturing representatives and customers supporting continuous improvement. Sherwood is your partner for the best quality valves, delivered on time, at the best possible price!**

# TABLE OF CONTENTS

6411 Series: Diaphragm Packless Lecture Bottle Valves .....	2
5074 Series: Brass Diaphragm Valves .....	3
6074 Series: 303 SS Diaphragm Packless Valves .....	4
6674 Series: 316L SS Diaphragm Valves .....	5
1214Y Series: Wrench-Operated, Corrosive Gas Valves .....	6
Low Pressure Brass Diaphragm Valves .....	7
Gases Chart .....	8



# 6411 Series

## Diaphragm Packless Lecture Bottle Valves

Sherwood's 6411 Series is designed specifically with corrosive gases in mind and with a durable construction for the specialty gases and gas mixtures used in laboratories.

- Proven leak-tight diaphragm seal
- Forged brass, aluminum silicon bronze and 303 stainless steel bodies withstand severe service conditions
- Low operating torque design ensures ease of operation during filling and use
- Available with standard CGA connections

### Diaphragm Packless Lecture Bottle Valves

Valve Series	Inlets	Outlets	Metallic Seat Material
6411 Brass Series	3/8"-18 NGT	CGA 170 180	303 Stainless Steel
6411X3 ASB Series	3/8"-18 NGT	CGA 180	303 Stainless Steel
6411X7 303 Stainless	3/8"-18 NGT	CGA 180	303 Stainless Steel

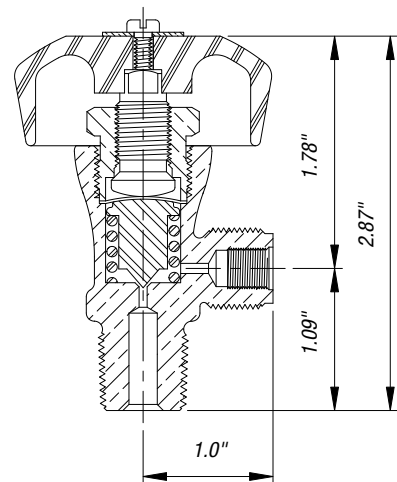

### Specifications

Max. Service Pressure	3000 PSIG	200 Bar
Temperature Range	-50° F → 120° F	-45° C → 49° C
Leak Rate	1x10 <sup>-7</sup> atm cc/sec.	1x10 <sup>-7</sup> Bar mL/sec.
Closing Torque	50 in.-lbs. @ 2000 PSIG	2.24 N-m @ 138 Bar
Cv	0.2 min.	0.2 min.

# 5074 Series Brass Diaphragm Valves

Sherwood's 5074 Series is designed for various high purity gases, UHP mixtures and pure gas applications.

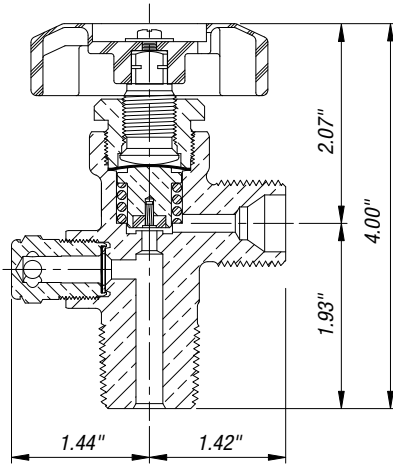

- Standardized anti-extrusion pin feature prevents seat extrusion and cold flow of the polymeric seat
- Available in multiple seat material configurations to accommodate all high-purity gas applications
- Increased flow (Cv) to aid in reducing vent and purge times
- Low operating torque design ensures ease of operation during filling and use
- Available with unitized pressure-relief device, which is equipped with a webbed washer design to protect the burst disc from damage during transportation and replacement
- Optional inlets equipped for dip tube assembly
- Available with standard CGA connections as well as international inlets and outlets

5074 X - (CGA) X X - B

<b>X =</b>
R = Tapped for Flow Restrictor
T = Tapped for Inlet Dip Tube
X15 = 1/8"-12 UNF Inlet (Straight Thread)
X75 = 3/4"-16 UNF Inlet (Straight Thread)

<b>PSIG</b>
A = 3000 PSIG
B = 3360 PSIG
C = 3775 PSIG
D = 4000 PSIG

<b>X = Temperature</b>
M = 165° Fuse Metal
W = 212° Fuse Metal

Certified Cleaned for Oxygen Service

## Brass Diaphragm Valves

Valve Series	Inlets	Outlets	Seat Material
<b>5074 Tapered</b>	3/4"-14 NGT	CGA	Nylon® 6/6 PCTFE PVDF
<b>5074X15 Straight Thread</b>	1/8"-12 UNF 3/4"-16 UNF	CGA	Nylon 6/6 PCTFE PVDF
<b>5074 International Series</b>	BS 341, DIN 477, ISO; All Others Available upon Request	CGA, BS 341, DIN 477, ISO; All Others Available upon Request	Nylon 6/6 PCTFE PVDF

## Pressure-Relief Device

<b>Burst Pressure @ 165° F</b>	A – 3000 PSIG
	B – 3360 PSIG
	C – 3775 PSIG
	D – 4000 PSIG
<b>Burst Disc Material</b>	Nickel 200 Copper
<b>Type</b> (per to CGA S1.1 latest edition)	None, Where Prohibited CG-1 Burst Disc Only CG-4 Burst Disc w/ 165° F Fuse Metal CG-5 Burst Disc w/ 212° F Fuse Metal

## Optional Features

- R = Outlet: Tapped for 5/16"-24 UNF Flow Restrictor
- T = Inlet Tap Available in 1/4", NPT or 10 mm
- B = Certified Cleaned for Oxygen Service

## Specifications

<b>Max. Service Pressure</b>	3000 PSIG	200 Bar
<b>Temperature Range</b>	-50° F → 130° F	-45° C → 54° C
<b>Leak Rate @ 2000 PSIG (138 Bar)</b>	1x10 <sup>-7</sup> atm cc/sec.	1x10 <sup>-7</sup> Bar mL/sec.
<b>Closing Torque</b>	50 in.-lbs. @ 2000 PSIG	5.6 N-m @ 138 Bar
<b>Cv</b>	.635	.635

# 6074 Series

## 303 SS Diaphragm Packless Valves

Sherwood's 6074 Series is designed for a variety of applications, including analytical & instrumentation gases, EPA protocol gases, environmental monitoring and medical applications using pharmaceutical gases.

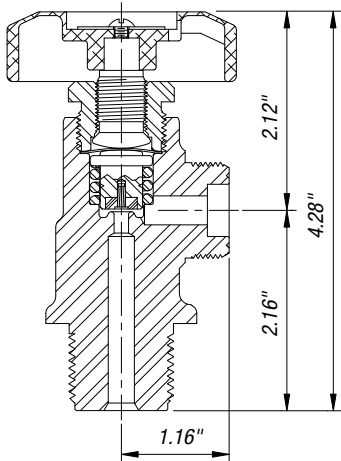

- Standardized anti-extrusion pin feature prevents seat extrusion and cold flow of the polymeric seat
- Available in multiple seat material configurations to accommodate all high-purity gas applications
- Increased flow (Cv) to aid in reducing vent and purge times
- Low operating torque design ensures ease of operation during filling and use
- Available with unitized pressure-relief device having fuse-metal backed or unbacked burst disc
- Optional inlets equipped for dip tube assembly
- Available with standard CGA connections as well as international inlets and outlets

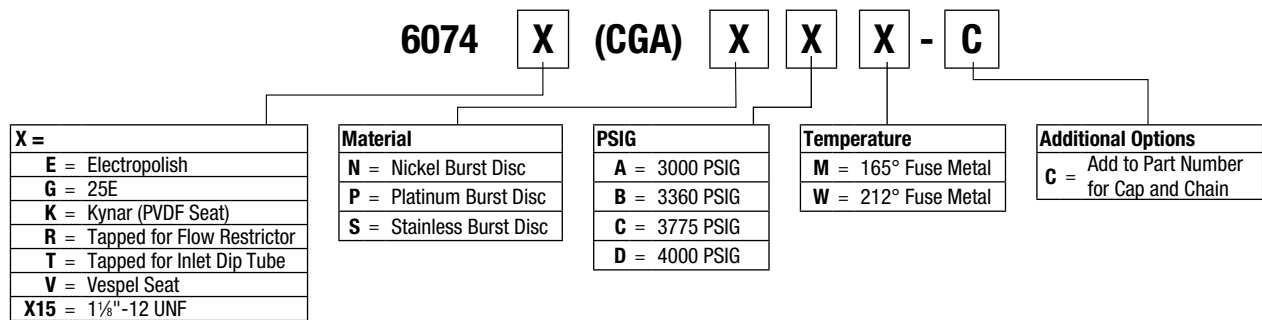

### 303 SS Diaphragm Packless Valves

Valve Series	Inlets	Outlets	Seat Material
<b>6074 Series</b>	3/4"-14 NGT	CGA	PCTFE
	5/8"-14 NGT		PVDF
<b>6074X15E Series</b>	1 1/8"-12 UNF-2A	CGA	PCTFE
			PVDF
<b>6074 International Series</b>	BS 341,	BS 341,	PCTFE
	DIN 477, ISO; All Others Available upon Request	DIN 477, ISO; All Others Available upon Request	PVDF

### Pressure-Relief Device

Burst Pressure @ 165° F	A – 3000 PSIG
	B – 3360 PSIG
Burst Disc Material	C – 3775 PSIG
	D – 4000 PSIG
Type (per CGA S-1.1 latest edition)	Nickel 200
	316L Stainless Steel
	Platinum-Clad Nickel
	None, Where Prohibited
	CG-1 Burst Disc Only
	CG-2 Fuse Plug 165° F Fuse Metal
	CG-4 Burst Disc w/ 165° F Fuse Metal
	CG-5 Burst Disc w/ 212° F Fuse Metal

### Optional Features

Aluminum Handwheel	Available in Red, Blue or Rubber Coated, and Chrome Plated 6 or 8 Lobed
Outlet	Tapped for 5/16"-24 UNF Flow Restrictor
Inlet Tap	Available in 1/4", NPT or 10 mm
Electropolishing of Gas Wetted Areas	

### Specifications

Max. Service Pressure	3000 PSIG	200 Bar
Temperature Range	-50° F → 130° F	-45° C → 54° C
Leak Rate @ 2000 PSIG (138 Bar)	1x10 <sup>-7</sup> atm cc/sec.	1x10 <sup>-7</sup> Bar mL/sec.
Closing Torque	50 in.-lbs. @ 2000 PSIG	5.6 N-m @ 138 Bar
Cv with Restrictor	.326	.326
Cv without Restrictor	.635	.635

# 6674 Series 316L SS Diaphragm Valves

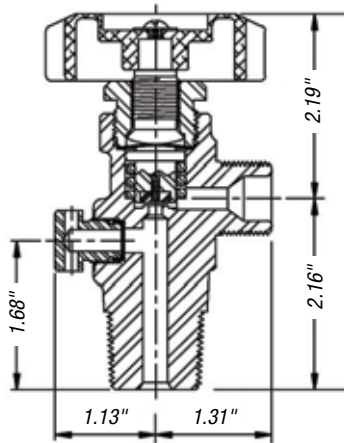

Sherwood's 6674 Series is used in corrosive gas applications, cylinder phosphine gas, atmospheric and purging gases, dopant gases and reactant gases.

- Crimped seat feature with anti-extrusion pin prevents seat extrusion and cold flow of the polymeric seat
- Available in multiple seat material configurations to accommodate all high-purity gas applications
- Increased flow (Cv) to aid in reducing vent and purge times
- Low operating torque design ensures ease of operation during filling and use
- Available with unitized pressure-relief device having fuse-metal backed or unbacked burst disc
- Available with standard CGA connections as well as international inlets and outlets

6674 X (CGA) X X X - C

X =
E = Electropolish
G = 25E
K = Kynar (PVDF Seat)
R = Tapped for Flow Restrictor
T = Tapped for Inlet Dip Tube
V = Vespel Seat
X15 = 1/8"-12 UNF

Material
N = Nickel Burst Disc
P = Platinum Burst Disc
S = Stainless Burst Disc

PSIG
A = 3000 PSIG
B = 3360 PSIG
C = 3775 PSIG
D = 4000 PSIG

Temperature
M = 165° Fuse Metal
W = 212° Fuse Metal

Additional Options
C = Add to Part Number for Cap and Chain

## 316L SS Diaphragm Valves

Valve Series	Inlets	Outlets	Seat Material
6674 Series	3/4"-14 NGT	CGA	PCTFE PVDF
6674 International Series	ISO, BS 341, DIN 477; All Others Available upon Request	ISO, BS 341, DIN 477, JIS	PCTFE PVDF

## Pressure-Relief Device

Burst Pressure @ 165° F	A – 3000 PSIG B – 3360 PSIG C – 3775 PSIG D – 4000 PSIG
Burst Disc Material	Stainless Steel – Standard Nickel 200 – Optional Platinum-Clad Nickel – Optional
Type (per CGA S-1.1 latest edition)	None, Where Prohibited CG-4 Burst Disc w/ 165° F Fuse Metal CG-5 Burst Disc w/ 212° F Fuse Metal

## Optional Features

Add an R or T to part number for options.  
For example, a 6674-330 with a tapped inlet would be 6674T-330.

R = Outlet Tapped for 3/16" Flow Restrictor

T = Inlet Tap Available in 1/4" NPT, 10 mm

Electropolish for Gas Wetted Areas

## Specifications

Max. Service Pressure	2400 PSIG	165 Bar
Temperature Range	-50° F → 130° F	-45° C → 54° C
Leak Rate @ 2000 PSIG (138 Bar)	1x10 <sup>-7</sup> atm cc/sec.	1x10 <sup>-7</sup> Bar mL/sec.
Closing Torque	50 in.-lbs. @ 2000 PSIG	5.6 N-m @ 138 Bar
Cv with and without Restrictor	.326/.635	.326/.635



# 1214Y Series

## Aluminum Silicon Bronze Packed Wrench-Operated Valves

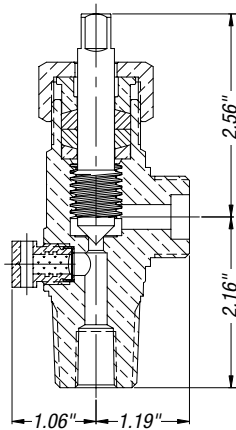

1214Y20T

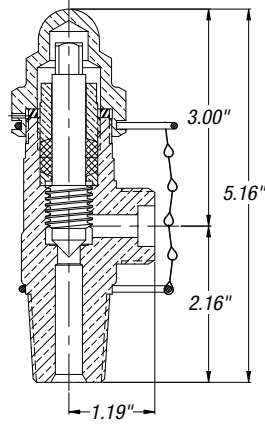

1214Y44

Sherwood's 1214 Series is designed for use in applications using chlorine gas, chlorine liquids, corrosive gases, insecticides & fumigants, preservatives and bleaching agents.

*\* Optional offering: Internal packing nut allowing for increased wall thickness and secondary seal cap (shown in second diagram)*

- Aluminum silicon bronze valve body offers proven resistance against various corrosive gases
- One-piece monel stem provides positive shutoff in corrosive gas service with exceptional durability
- Teflon® packing promotes easy operation while providing a durable leak-resistant stem seal
- Optional tapped inlet threads for dip tube assembly
- Available with standard CGA connections as well as international inlets and outlets
- Available with unitized pressure-relief device having fuse metal backing

### Packed Wrench-Operated Valves

Sherwood Part Number	Inlet Thread Size	Outlet Designation	PRD	Features	CV
1214Y26B	3/4"-14 NGT	330	None	1/4" Inlet Tap; Cap and Chain Oxygen Cleaned	.880
1214Y42	3/4"-14 NGT	330	3360 PSIG, CG-5	Cap and Chain	.880
1214Y9R-330PxM	3/4"-14 NGT	330	CG-4, x = Burst Pressure Rating (see chart below)	—	.880
1214Y24	3/4"-14 NGT	330	None	1/4" Inlet Tap Secondary Seal Cap	.880
1214Y41B	3/4"-14 NGT	330	None	Oxygen Cleaned Outlet Cap and Chain	.880
1214F6	3/4"-14 NGT	660	None	—	.880
1214Y20T	3/4"-14 NGT	660	3360 PSIG, CG-4	1/4" Inlet Tap	1.482
1214Y44	3/4"-14 NGT	679	None	Secondary Seal Cap Oxygen Cleaned	1.885
1214Y3-SB	3/4"-14 NGT	670/679	None	Oxygen Cleaned	1.885

### Pressure-Relief Device

	Specifications		
Burst Pressure @ 165° F	A – 3000 PSIG B – 3360 PSIG C – 3775 PSIG D – 4000 PSIG	Max. Service Pressure	3000 PSIG      200 Bar
Burst Disc Material	Platinum-Clad Nickel	Temperature Range	-50° F → 120° F      -45° C → 49° C
Type (per CGA S-1.1 latest edition)	None, Where Prohibited CG-2 Fuse Plug 165° F Fuse Metal CG-4 Burst Disc w/ 165° F Fuse Metal CG-5 Burst Disc w/ 212° F Fuse Metal	Leak Rate @ 2000 PSIG (138 Bar)	1x10 <sup>-6</sup> atm cc/sec.      1x10 <sup>-6</sup> bar mL/sec.
		Closing Torque @ 2000 PSIG (138 Bar)	15 ft.-lbs.      5.6 N-m

# 1032 Series

## Low Pressure Brass Diaphragm Valves

Sherwood's 1032 Series is designed for use in liquefied gas applications, including refrigerants and flammables, and is especially suitable for propane, butane and fuel-gas applications but also sterilant gas applications.

- High-density forged brass body and two non-perforated stainless steel diaphragms for durability
- Spring-loaded Type CG-7 safety for use on liquefied gas cylinders having water capacities not exceeding 254 lbs.
- Nylon seat insert and controlled stem travel assure positive shut-off and long, wear-resistant service
- Inlet and outlet connections comply with CGA V-1 Specifications
- Assembly torque: Bonnet 60 ft-lbs

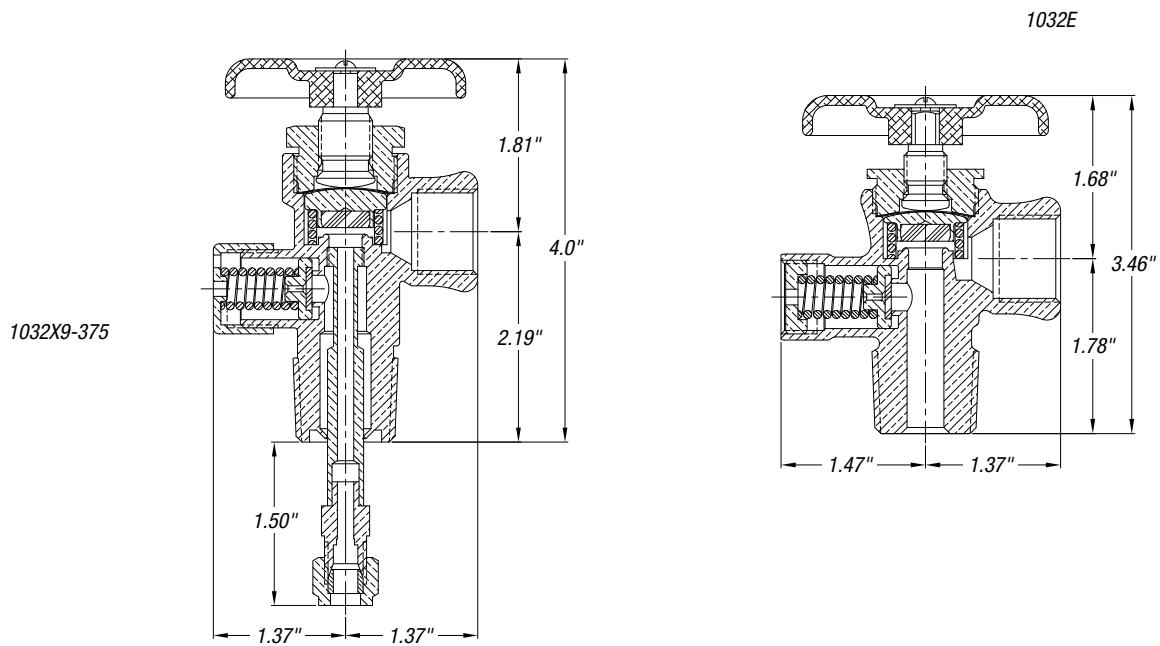

### Low Pressure Brass Diaphragm Valves

Sherwood Part Number	Outlet Connection	Inlet Connection	Inlet Tap	Safety Type	Start to Discharge Setting (PSIG)	Seat Material	PRD Material	Special Features
1032E	510	3/4"-14NGT	—	CG-7	375	Nylon	Buna-N	Low Profile
1032X5	510	3/4"-14NGT	1/4" - 18 NPT	CG-7	375	PCTFE	Teflon	—
1032X8	510	3/4"-14NGT	1/8" - 27 NPT	CG-3	212° F	Teflon	—	—
1032X9-375	510	3/4"-14NGT	—	CG-7	375	Nylon	Buna-N	Dip Tube, Charge Port
1032X9-450	510	3/4"-14NGT	—	CG-7	450	Nylon	Buna-N	Dip Tube, Charge Port
1042X6	510	3/4"-14NGT	1/4" - 18 NPT	No PRD	—	PCTFE	—	—
1042X6T	510	3/4"-14NGT	1/4" - 18 NPT	No PRD	—	Teflon	—	—

# GASES CHART

Gases	CGA	Valve Series	Material
Oxidizing Mixtures	296	5074	Brass
Carbon Dioxide	320	6074	303 SS
	320	6674	316L, SS
Nitrous Oxide	326	5074	Brass
	326	6674	316L
Boron Trifluoride, Hydrogen Bromide, Hydrogen Chloride, Hydrogen Sulfide, Methyl Bromide, Methyl Mercaptan, Nitrogen Trifluoride, Nitryl Fluoride, Sulfur Tetrafluoride	330	6074	303 SS
	330	6674	316L, SS
Air	346	5074	Brass
	346	6674	316L, SS
	350	5074	Brass
Arsine, Carbon Monoxide, Deuterium, Diborane, Ethane, Ethylene, Germane, Hydrogen, Hydrogen Selenide, Methane, Methyl Fluoride, Natural Gas, Pentaborane, Phosphine, Silane	350	6074	303 SS
	350	6674	316L, SS
Blood Gas Mixtures, Lung Diffusion Mixtures, Noncorrosive Gas Mixtures Labeled as Drugs or Medical Devices	500	5074	Brass
Oxygen	540	5074	Brass
Argon, Helium, Krypton, Neon, Nitrogen, Xenon	580	5074	Brass
	580	6074	303 SS
Sulfur Hexafluoride	590	5074	Brass
	590	6074	303 SS
Medical Device Mixtures, Nitric Oxide Mixtures, Nitrogen Dioxide Mixtures	625	6074	303 SS
Therapeutic Nitric Oxide Mixtures Labeled as Drugs	626	6074	303 SS
Boron Trichloride, Carbonyl Fluoride, Ethyl Fluoride, Hexafluoropropylene, Hydrogen Cyanide, Nickel Carbonyl, Nitric Oxide, Nitrogen Dioxide, Nitrogen Trioxide, Phosgen, Sulfur Dioxide, Sulfuryl Fluoride, 1,1,2,2 Tetrachlorodifluoroethane (R112), Trichlorofluoromethane (R11)	660	5074	Brass
	660	6074	303 SS
	660	6674	316L, SS
Dichlorosilane	678	6674	316L, SS
Fluorine, Oxygen Difluoride, Tetrafluorohydrazine, Trifluoromethyl Hypofluorite	679	6674	316L, SS
Ammonia (R-717), Dimethylamine, Monoethylamine (R-631), Monomethylamine (R-630), Trimethylamine	705	6074	303 SS
	705	6674	316L, SS

# GASES CHART