

# RegO® - LNG Angle Pressure Relief Valve AR Series

## Application

The ASME approved 90° relief valves AR Series, provide precise control set points which protect cryogenic vessels and piping systems for over-pressurization.

## Features

- High flow rates are approved by rigorous testing to ASME Code VIII.
- The ninety degree configuration provides relief of LNG gases directly avoiding flow through the spring.
- Bubble tight seat provides 100% shut off when reseating or static mode.
- A variety of inlets and pressure settings assure adherence to application requirements.
- Temperature Range: -320°F (-196°C) to +165°F (+74°C)
- Cleaned for Liquid Oxygen Service per CGA G-4.1
- 100% Factory Tested.

## Materials

Body .....	Bronze ASTM B61
Upper Body.....	Stainless Steel ASTM A582
Seat & Stem .....	Brass ASTM B16
Poppet Guide.....	Brass ASTM B16
Spring Retainer.....	Brass ASTM B16
Adjusting Screw .....	Brass ASTM B16
Cap .....	Brass ASTM B16
Ball.....	Stainless Steel
Upper Gasket .....	PTFE ASTM D4894
Lower Gasket .....	Copper ASTM B152-17
Spring .....	Stainless Steel ASTM A313

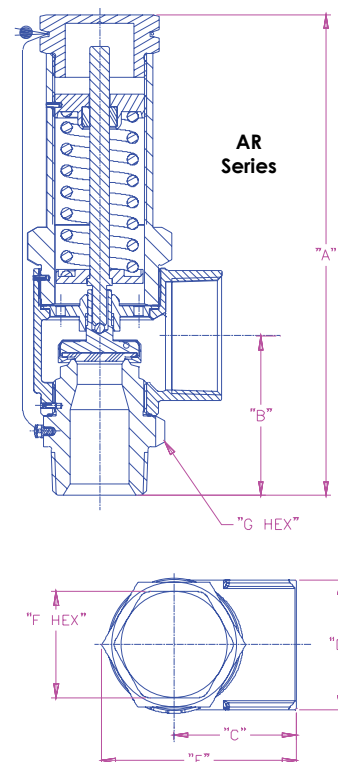

## Ordering Information

Part Number	Inlet Inches DN (mm)	Outlet Inches DN (mm)	Ends	A Inches (mm)	B Inches (mm)	C Inches (mm)	D Inches (mm)	E Inches (mm)	ASME Flow Capacity SCFM/Air @ 250 PSI *	Weight Lbs (Kg)
AR4104A	½" (15)	1" (25)	Thread NPT	6.03" (153.16)	1.97" (50.04)	1.63" (41.40)	1.63" (41.40)	2.49" (63.25)	450	2.75 (1.25)
AR4106A	¾" (20)			6.88" (174.75)	2.37" (60.20)	2.00" (50.80)	1.90" (48.26)	3.01" (76.45)		1,003
AR4108A	1" (25)	1¼" (32)		9.64" (244.86)	3.20" (81.28)	2.45" (62.23)	2.60" (66.04)	3.89" (98.81)	2,277	8.00 (3.63)
AR4112A	1½" (38)	2" (50)								