

Aluminum Pressure Regulators

1682M Series C-1682M Series

Application

The 1682M Series Regulators are designed primarily for second stage regulation of a variety of gases in industrial piping systems, hospital piping systems and manifold systems.

The C-1682M Series is specifically designed for use with Carbon Dioxide.

Features

- Maximum inlet pressure is 400 PSIG.
- Two 1/4" F.NPT gauge ports are located 180° apart to allow for gauge mounting in the most convenient positions.
- Each 1680M Series regulator is cleaned and packaged per CGA G-4.1.

Materials

Body.....Forged Aluminum
 Bonnet.....Cast Aluminum
 Seat Disc (1682M).....Neoprene
 (C-1682M).....EPDM
 Diaphragm (1682M).....Neoprene
 (C-1682M).....EPDM



Ordering Information

Part Number		Delivery Pressure Range (PSI)	Pressure Gauge		Inlet & Outlet Conn. (F.NPT)	Width A	Maximum Height B
			Range (PSI)	Part Number			
1682ML	C-1682ML	5-50	*	*	1/4"	2 3/16"	4 1/8"
1682MLG	C-1682MLG		1-100	1286			
1682M	C-1682M	50-125	*	*			
1682MG	C-1682MG		1-200	S1679			
1682MS	C-1682MS	100-250	*	*			
1682MSG	C-1682MSG		1-400	15578			

* Pressure gauge not included.

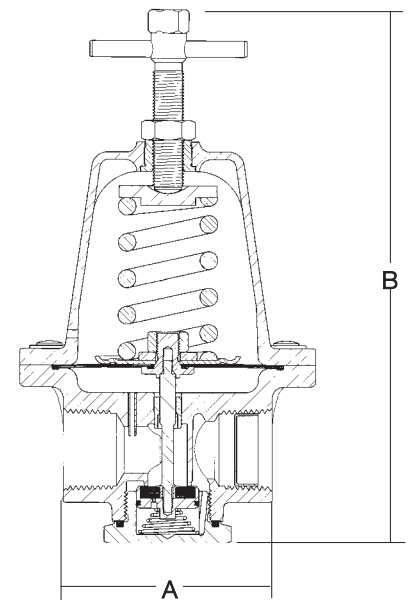

1682M SERIES REGULATOR FLOW PERFORMANCE

